



Ammonia Gas Module 0~100ppm

TB600C-NH₃-100

Technical Specification

» Product Overview

The TB600C-Series Ammonia Gas Module is the perfect combination of a state-of-the-art high-precision sensing device with a sophisticated circuit board. The sensor module uses EC Sense's small-in-size solid polymer electrochemical sensor, which accurately detects very low concentrations of gases. It replaces our nose to reliably sniff out the gas concentration and enables precise gas detection. The TB600C module serves an UART digital output for ease-of-use, eliminating the need for customers to understand the sensor application and the tedious work of calibration.

» Features

- ☞ Non-consumable long-life design, can be used stably in long-term exposure to ammonia concentration environment
- ☞ Resistant to high humidity applications, can be used stably in a high humidity environment above 85% for a long time
- ☞ Wide temperature range from -40 to 55°C
- ☞ Anti-interference, can achieve high-precision measurement in complex gaseous environment
- ☞ Independent temperature and humidity digital sensors output, combined with intelligent algorithms, stronger environmental adaptability
- ☞ Fast response, fast return to zero, plug and play
- ☞ Easy to use, UART digital signal output, zero drift
- ☞ Durable and reliable, long lifetime and stable detection
- ☞ New microcircuit design, strong anti-electromagnetic interference ability, good anti-toxicity
- ☞ With fixed mounting holes for easy installation
- ☞ Low power consumption and sleeping mode (suitable for and IoT applications)
- ☞ RoHS approved eco-friendly design

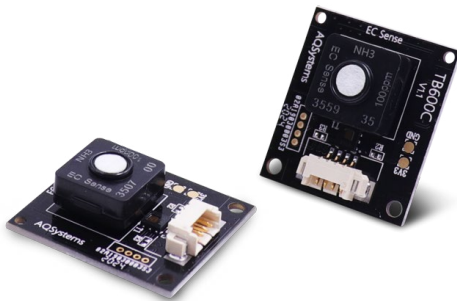

» Application

- ☞ Livestock breeding (pig house, chicken house, cattle farm environment, etc.)
- ☞ Smart public toilet ammonia odor monitoring
- ☞ Ammonia monitoring in landfill plants and sewage treatment plants



» Principle

The EC Sense solid polymer electrochemical technology is a revolutionary innovation in the field of electrochemical detection. This technology is based on the principle of electrochemical catalytic reaction, detecting the output signals of the electrochemical reactions of different gases and accurately measuring the gas concentration through the signal.

The sensor is composed of three electrodes in contact with the electrolyte. A typical electrode consists of a large surface area of noble metal and other materials. The electrode, electrolyte and the surrounding air are in contact and the gas diffuses into the working electrode. Here the gas will be oxidized, this causes a current, which is proportional to the gas concentration.

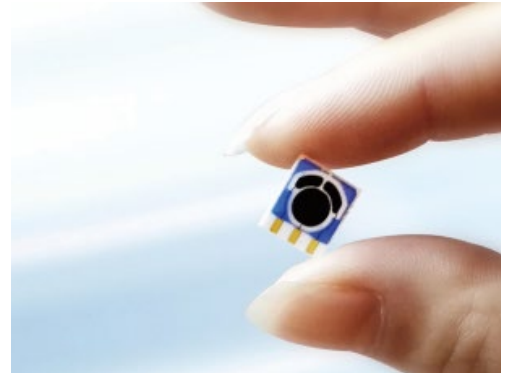

» Order Information

Product	Part Number	Range	Resolution
Ammonia Gas Module	04-TB600C-NH ₃ -100-01	0-100ppm	0.1ppm
4Pin Cable	02-MOD-CABLE-4PIN-01		

» Structure Diagram

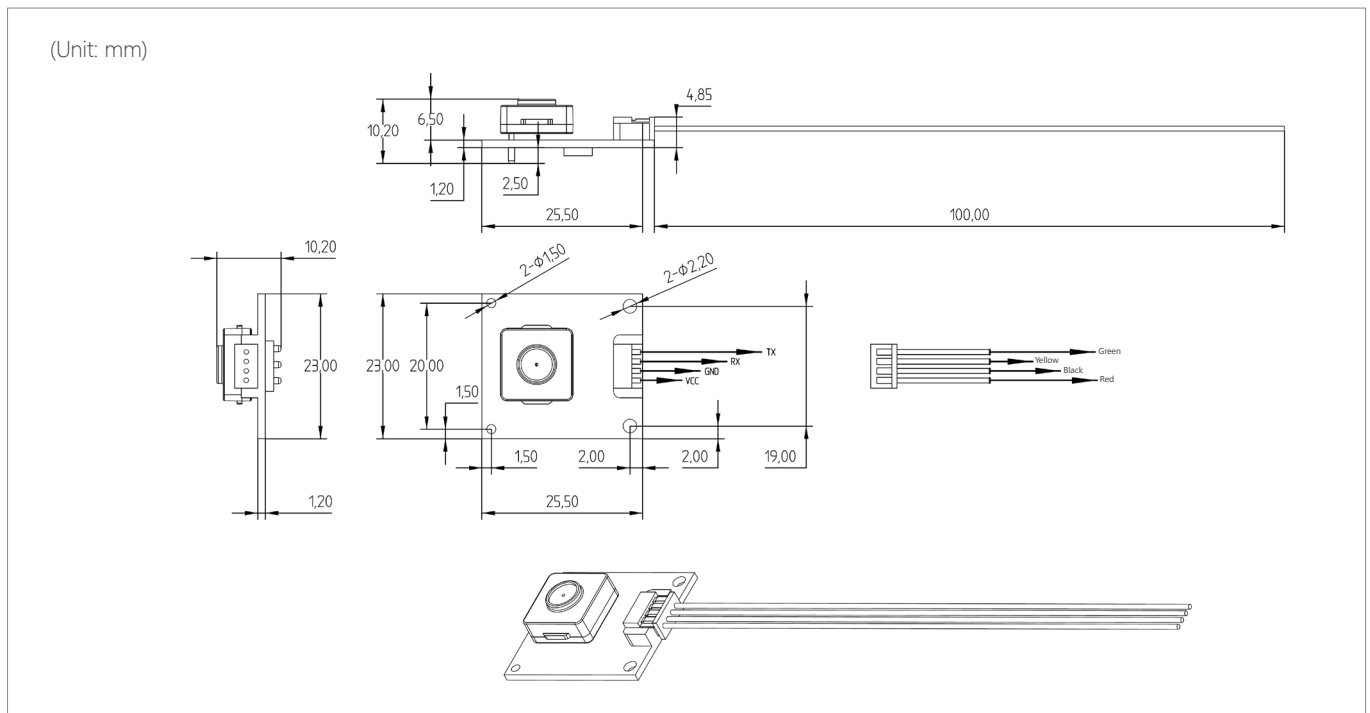

» Specification

Principle	Solid Polymer Electrochemical Sensing Technology
Order Number	04-TB600C-NH ₃ -100-01
Detection of Gas	NH ₃ Ammonia Gas
Detection Range	0-100ppm; Display resolution: 0.1ppm
Lowest Detection Limit	0.1ppm;
Full-Scale Accuracy Error	± 5%
Warm-Up Time	Stored in clean air for the first time power on < 5 minutes
Response Time	< 3 seconds
Calibration Substance	100ppm measurement range: 50ppm Ammonia gas calibration; Note: The smaller the range, the higher the detection accuracy. It is not recommended for users to use it beyond the range.
Sensor Storage Life	> 3 years
Expected Sensor Lifetime	> 2 years (in a relatively clean environment at room temperature and humidity, no need for vacuum storage)
Relative Temperature Error	± 0.2°C
Relative Humidity Error	± 2%
Output	3.3V UART digital signal (see below for communication protocol) Interface definition: VCC- red, GND- black, RX- yellow, TX- green; Baud rate: 9600 Data bits: 8 bits Stop bits: 1 bit;
Get Data Command	Communication has active upload and Q & A mode. The default mode is Q & A mode after power-on. You can use instructions to switch between the two modes. Or Q & A mode is restored by power off or switch power mode
Working Voltage	3.3 - 5.5V DC
Working Current	< 5mA
Power Consumption	Ad sleeping mode power consumption 25mW @ 5V ad Q&A mode power consumption
Repeatability	Full range 100ppm ± 1% is the normal range
Working Temperature	0°C to 40°C , suitable for indoor use. -20°C to +55°C , need for temperature compensation
Optimal Working Temperature	20°C to 35°C
Working Humidity	15% - 95% RH. (Non-condensing)
Optimum Working Humidity	50% RH.
Working Pressure	Atm ± 10%
Board Size	23 x 25.5 x 10.2mm (with sensor)
Board Size	23 x 25.5 x 4.85mm (without sensor)
Weight	3.1g
Signal Cable	The standard length is shown in the structure diagram and can be customized if there are special requirements.

Disclaimer

The EC Sense performance data stated above is based on data obtained under test conditions using the EC Sense gas distribution system and AQS test software. In the interest of continuous product improvement, EC Sense reserves the right to change design features and specifications without notice. We are not responsible for any loss, injury or damage caused by this. EC Sense assumes no responsibility for any indirect loss, injury or damage resulting from the use of this document, the information contained therein or any omissions or errors herein. This document does not constitute an offer to sell. The data it contains are for informational purposes only and cannot be considered a guarantee. Any use of the given data must be evaluated and determined by the user to comply with federal, state and local laws and regulations. All specifications outlined are subject to change without notice.

 **Warning**

EC Sense sensors are designed for use in a variety of environmental conditions. However, due to the principles and characteristics of solid polymer electrochemical sensors and to ensure normal use, users must strictly follow this article during storage, assembly and operation of the module. General-purpose PCB circuit board application methods and illegal applications / violation of the application will not be covered by the warranty. Although our products are highly reliable, we recommend checking the module's response to the target gas prior to utilization to ensure on-site use. At the end of the products service life, please do not discard any electronics in the domestic waste, instead follow the local governments electronic waste recycling regulations for disposal.



**Business Centre
Europe and the rest of the world**

EC Sense GmbH
Wangener Weg 3
82069 Hohenschäftlarn, Germany
Tel: +49(0)8178-99992-10 Fax: +49(0)8178-9999-211
Email: office@ecsense.com
www.ecsense.com www.ecnose.de

**Business Centre
Asia**

Ningbo AQSystems Technology Co., Ltd.
F4-17 Buliding, Zhong Wu Technology Park No.228,
Jin Gu Bei Road, Yinzhou District NingBo,
Zhejiang Provence, P.R. China Post Code: 315100
Tel: +86(0)574 88097236, 88096372
Email: info@aqsystems.cn
www.ecsense.cn, www.ecnose.com